

# Dispensers

## For steel strapping



Model	Part Number	Strap Size		Coil Winding		Weight	
		inch	mm	Mill	Ribbon	lbs	kg
DF-15*	273725	3/8-3/4	9.5-19.0	•	—	54.5	24.7
DF-10RW	020420	3/4-1-1/4	19.0-31.8	•	•	94	43
DF-23	024200	3/8-3/4	9.5-19.0	•	—	35	16
DM-23**	017000	—	—	—	—	—	—
DTR-3	164520	3/4-2	19.0-50.8	—	•	110	50
DT-1-10RW	011442	5/8-1-1/4	15.9-31.8	•	•	125	57
DH-1-34	047538	3/4	19.0	—	•	46	21
DH-1-114	047537	1-1/4	31.8	—	•	46	21
DH-1-2	047539	2	50.8	—	•	46	21

\* Dispenser can be used with both steel and plastic strapping

\*\* Makes the DF-23 mobile. (Part No. 017000)



**DF-15**  
For typical shipping room. Easily loaded with mill wound coils.



**DF-10RW**  
Accepts mill wound or ribbon wound coils 3/4" and 1-1/4" in width.



**DF-23**  
Fits almost anywhere. Pays off from the inside of the coil. Mobile with optional DM-23 cart. Cover required for strap over 0.023" (0.58mm). Cover sold separately (Part No. 024219).



**DM-23**  
Makes the DF-23 mobile.



**DTR-3**  
Heavy-duty carloading. Rubber tires for easy mobility. Holds one coil 3/4", two coils 1-1/4", and one coil 2" strapping.



**DT-1-10RW**  
Heavy-duty dispenser. Ideal for outdoor use in rough terrain.



DH-1-34, DH-1-114, DH-1-2  
For use with heavy-duty strapping.

Model	Part Number	Strap Size		Coil Winding		Weight	
		inch	mm	Mill	Ribbon	lbs	kg
DA-34-114	020400	3/4-1-1/4	19.0 or 31.8	—	•	131	59
DF-1-12	031317	3/8-3/4	9.5-19.0	•	—	95	43
DF-X*	429220	1/2-3/4	12.7-19.0	•	—	58	26
DP-1-12R	040900	3/8-3/4	9.5-19.0	•	—	170	77
DC-1A	005720	3/4-2	19.0-50.8	—	•	97	44
DPCL	083001	3/8-2	9.5-50.8	•	•	450	204

\* Dispenser can be used with both steel and plastic strapping



**DF-1-12**  
For power equipment only. Dancer arm of coil and brake. Base sold separately (Part No. 024360).



**DA-34-114**  
Heavy-duty dispenser. Pays off from inside of coil.



**DF-X**  
An all purpose, easy loading dispenser for mill wound coils.



**DP-1-12R**  
Pneumatic reversing dispenser. Generally for power strapping machines with large chute systems.



**DC-1A**  
Built-in strap cutter for pre-cutting. Holds any two ribbon wound coils.



**DPCL**  
Cuts strapping automatically up to 100 ft. in length.

# Pneumatic Accessories

For steel and plastic strapping

**SIGNODE®**

## Pneumatic accessories



**Note: Only use lightweight air tool oil in lubricator, such as Non-fluid Oil No. L0713-54 (Part No. 008556).**

A filter-regulator-lubricator (FRL) assembly (**Part No. 429141**, with 1/2" I.D. hose) or (**Part No. 429130**, without hose) is needed with all pneumatic tools and equipment. Additional pneumatic accessories are available from Signode, such as those shown on right, to help provide optimum operation. Please contact your local Signode sales representative for more information on the proper fittings for your specific tool or equipment.

Check the air pressure at the tool with a separate air gauge to verify proper air pressure.



Standard air gauge. (**Part No. 425238**)



Quick-connect safety socket for standard air supply. (**Part No. 429134**)



Quick-connect plug for low standard air supply. (**Part No. 020704**)



High air flow gauge. (**Part No. 429127**)



Quick-connect socket for high flow air supply. (**Part No. 015294**)



Quick-connect plug for high flow air supply. (**Part No. 015293**)

## Recommended Air Line Piping

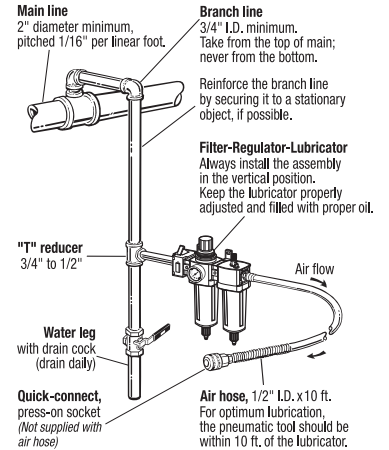

Bi-directional 360° swivel connector for increased operator control and maneuverability. (**Part No. 426903**)



Filter bushing (**Part No. 024631**) Screened bushing reduces air line particles from entering the tool.

# Steel Strapping Accessories

## Coil Lifter

Capable of lifting up to 125 lb. strap coils, the standard coil lifter is designed for easy dispenser loading, both vertically and horizontally. Accommodates both mill and ribbon wound steel strap coils as well as standard plastic coils.



**Portable model**  
Part No. 424700



**Stationary model**  
Part No. 425650

## Strapping Cutters



**Model CU-25**  
Part No. 005740  
For strap removal or cutting strap to length. Replaceable blades. Cuts strap through 2" x 0.050" (50.8 x 1.27 mm). Shipping weight: 8 lbs. (3.6 kg)



**Model CU-25LH**  
Part No. 0X-1528  
Extra long handle cutter. Replaceable blades. Cuts strap through 2" x 0.050" (50.8 x 1.27 mm). Shipping weight: 8 lbs. (3.6 kg)



**Model CU-30**  
Part No. 005899  
Lightweight. One-hand operation. Cuts strap through 1-1/4" x 0.035" (31.8 x 0.89 mm). Shipping weight: 3 lbs. (1.35 kg)



**Model CY-30**  
Part No. 426010  
Heavy-duty alloy steel. Cuts strap through 1-1/4" x 0.035" (31.8 x 0.89 mm). Shipping weight: 3 lbs. (1.35 kg)

### Battery-Operated Friction-weld

The BXT2 combination tools apply polypropylene or polyester strapping, utilizing friction weld joint technology to join strap ends. Automatic weld function speeds up cycle time. The battery-operated BXT2 has a simple two-button process and ergonomic design to reduce operator fatigue.

Model	Part Number	Strap Type				Description	Applied Tension lbs.		Joint Type	Approx. Shipping Weight	
		Contrax		Tenax			lbs	N		lbs	kg
		inch	mm	inch	mm						
BXT2-10	800570	3/8-1/2	9-13	3/8-1-2	9-15.9	Battery	275	1 223	Friction-weld	7.5	3.4
BXT2-16	428340	—	—	1/2-5/8	12.7-15.9	Battery	550	2 446	Friction-weld	9	4.1
BXT2-19	428350	—	—	5/8-3/4	15.9-19.0	Battery	880	3 914	Friction-weld	9	4.1
BXT2-25	2640315	—	—	1	25.4	Battery	1,460	6 494	Friction-weld	14.3	6.5
BXT2-32	2640325	—	—	1-1/4	32	Battery	1,460	6 494	Friction-weld	14.3	6.5



BXT2-10



BXT2-16  
BXT2-19



BXT2-25/32

## Dispensers

Model	Part Number	Strap Size		Core Size I.D.	Dispenser Weight	
		inch	mm		lbs	kg
DD-1A	024520	7/16-1/2	10.5-12	16"	48	22
DF-16A	422300	3/8-3/4	9-19.0	16"	62	28
DF-1-12D	031318	3/8-3/4	9-19.0	16"	97	44
DF-X	429220	1/2-3/4	12.7-19.0	16"	58	26

**DD-1A**  
Floor model with straproller. Can be suspended overhead.



**DF-16A**  
Designed for use with high-strength polyester strapping.



**DF-1-12D**  
For power equipment. Dancer arm and brake. Base sold separately (Part No. 024360).



**DF-X**  
An all purpose, easy loading dispenser for mill wound coils.



### Pneumatic tool accessories

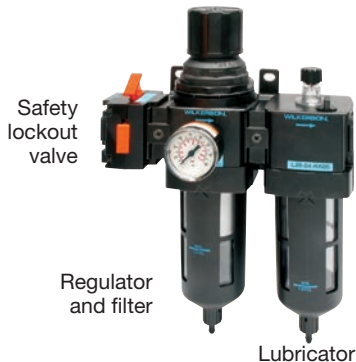

See Page 14 for additional fittings.

A filter-regulator-lubricator (FRL) assembly is needed with all pneumatic tools and equipment. Additional pneumatic accessories are available from Signode to help provide optimum operation. Please contact your Signode sales representative for more information on the proper fittings for your specific tool or equipment.

Note: Only use light weight air tool oil in lubricator, such as Non-fluid Oil No. L0713-54 (Part No. 008556) or equivalent.